

ANDERSEN Winches

Manual for Conversion Kits

28STE Compact & 2+1 SE	2
40STE Compact & 2+1 SE	5
46STE Compact Above Deck up to version 3.2.....	7
46ST version 3.2 to 4.0 winch with drive unit.....	8
52ST/ST FS Electric or Hydraulic Below Deck Conversion Kit	9
52STE Compact Above Deck Version	10
58/62STE Compact Above Deck Version	13
68/72STE Compact.....	15

28STE Compact & 2+1 SE

These instructions will guide you through the procedures to prepare your winch for use with an ANDERSEN Compact/ 2+1SE motor. This involves changing the bottom ratchet gear so that the winch can be coupled to your new motor. Winches older than November 2002 will also require a new winch base (supplied with your motor).



Remove your winch from the boat and find a clean and stable spot to work on your winch. As you disassemble your winch, as described below, carefully clean each part with degreaser. While reassembling apply a thin layer of Andersen Winch Grease to all moving part.

Tools: Flathead screwdriver, winch-handle and ANDERSEN Winch Grease. (Newer winches require a 4mm Alan key)

1. Loosen the screw on top of the winch and remove the drum.
2. Remove the shaft by pulling it upwards, twisting it as you go. A winch handle can be helpful. You can then remove the top ratchet gear.



3. Remove the shaft ring and the roller bearing by sliding it up over the winch base. You can then remove the gear wheel.



4. Remove the circlip holding the bottom cap. The bottom cap will then fall into the winch and you can slide the cap out through the side of the winch. The old bottom ratchet gear can now fall out the bottom of the winch.



5. If your winch is older than November 2002 discard your old base and take the new base supplied with your motor. For newer winches clean your old base before reassembling.

6. With the winch base upside-down, place the new bottom ratchet gear in the bottom of the base. Turn your winch over and place the gear wheel in position and secure it with the roller bearing and the shaft ring.

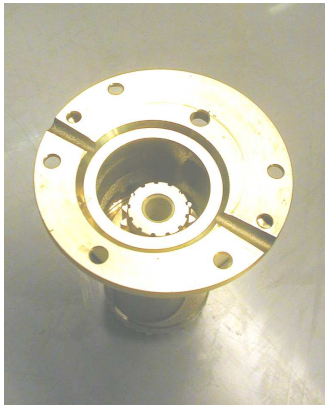

7. Slide the top ratchet gear into place then with a twisting motion insert the drive shaft through the base until it falls to the bottom.



8. Your winch is now ready to be installed with your new compact/ 2+1 SE motor.

40STE Compact & 2+1 SE

For 2003 winches on

Tools: Flathead screwdriver, hammer, punch and grease



1. Loosen the 3 screws on top of the winch and remove the drum.
2. Remove the roller bearing by sliding it up over the winch base.
3. Loosen the screw that holds the side cogwheel and remove it.



Step 3



Step 4

4. Place winch base in a vice or have someone hold it firmly. With a punch from a hammer, loosen the threaded bottom cap anti clockwise, and remove it.
5. Remove the old free running cogwheel from the bottom of the winch.

6. After applying grease, insert the newly supplied free running cogwheel onto the main shaft using a twisting motion so that the pawls fall into place. Be careful! The ratchet cogwheel can fall out before step 8 is complete.

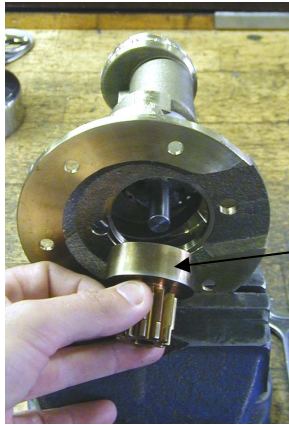

Step 6

Free running cogwheel

7. Replace the side cogwheel and the roller bearing after cleaning and greasing all moving parts. Grease the ball bearings on the top of the winch base.
8. Your winch is now ready to be installed with your new compact/2+1 SE motor. Install the winch before replacing the drum.



46STE Compact Above Deck up to version 3.2

Tools required for this conversion:

Allen keys 4mm and 5mm

Small screwdriver

Winch-handle

1. Remove the winch from its mounted position. Place the winch drum and self-tailing arm to one side.
2. Remove the 6 or 9 screws holding the upper base to the lower base. (Figure 1)
3. Remove the drive shaft from the upper base by pulling the shaft upwards. To do this you can use a winch handle to pull on the shaft. An o-ring stops the drive shaft from falling out so some resistance should be expected when removing the drive shaft. (Figure 2)
4. Turn the upper base upside down and remove the 2 free gear assemblies by unscrewing the axels in the upper base. (Figure 3)
5. Remove the complete roller bearing by sliding the ring upwards. (Figure 4)
6. The old upper and lower bases are no longer required.
7. Reassemble the winch with the new upper and lower base provided with your compact motor. While the winch is disassembled it may be appropriate to carry out a general service on the winch as described in the 46ST manual. In all cases the gears should be cleaned and new grease applied to all moving parts.
8. After first securing your new Compact Electric Motor to the deck, the converted winch can now be mounted on the motor with the screws provided.

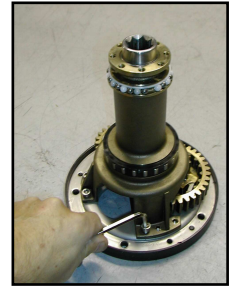

Figure 1

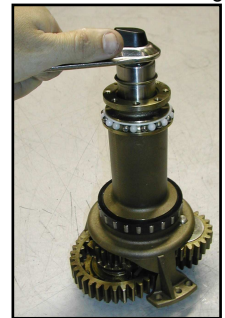

Figure 2

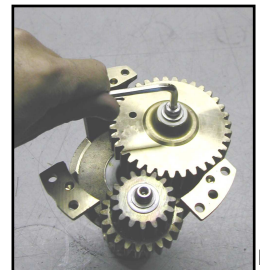

Figure 3

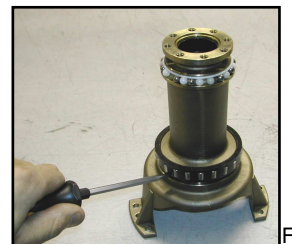

Figure 4



Figure 5, Parts to be mounted on the new upper base

46ST version 3.2 to 4.0 winch with drive unit

IMPORTANT INFORMATION when mounting a new winch with a drive unit.

With the 46ST version 4.0, we have integrated the deck plate features in the winch base plate.

With the new deck plate there is a distance ring, which gives the correct height from the unit to the winch, see the installation drawing below.

46ST up to version 3.2

Type with deck plate

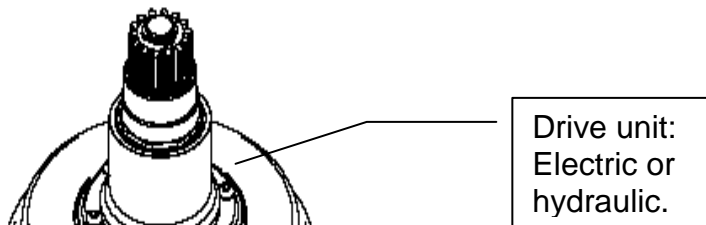
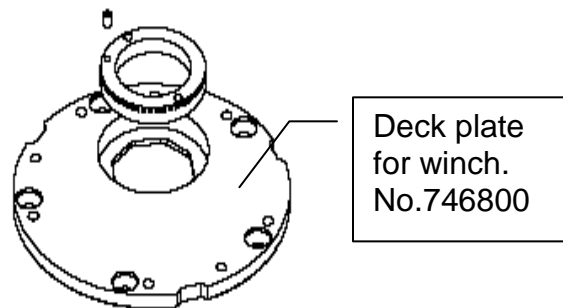

46ST from version 4.0

Type without deck plate

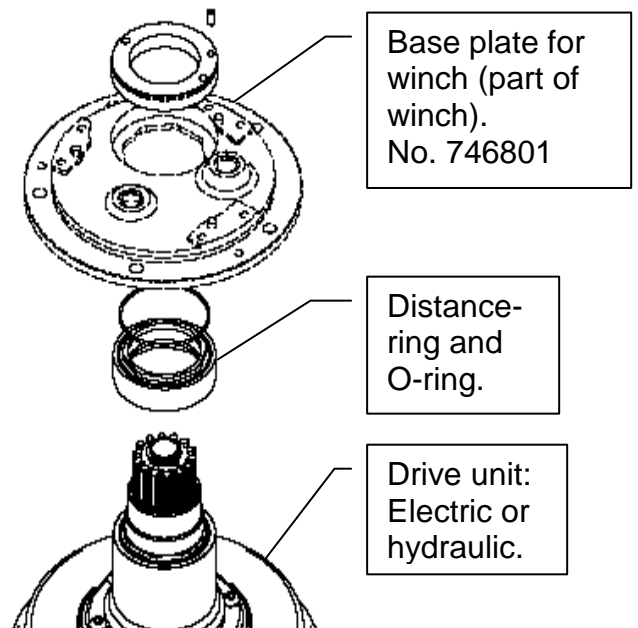

HOW TO INSTALL WINCH 52ST/ST FS WITH AN ELECTRIC OR HYDRAULIC BELOW DECK CONVERSION KIT

52ST/ST FS version 2.5
(or earlier version)

52ST/ST FS version 3.0
(or later version)

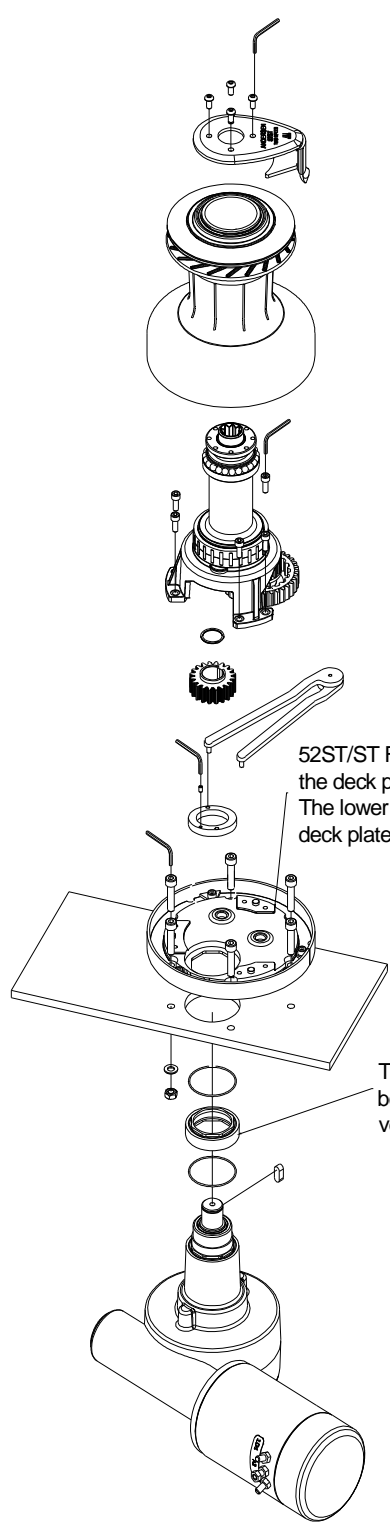
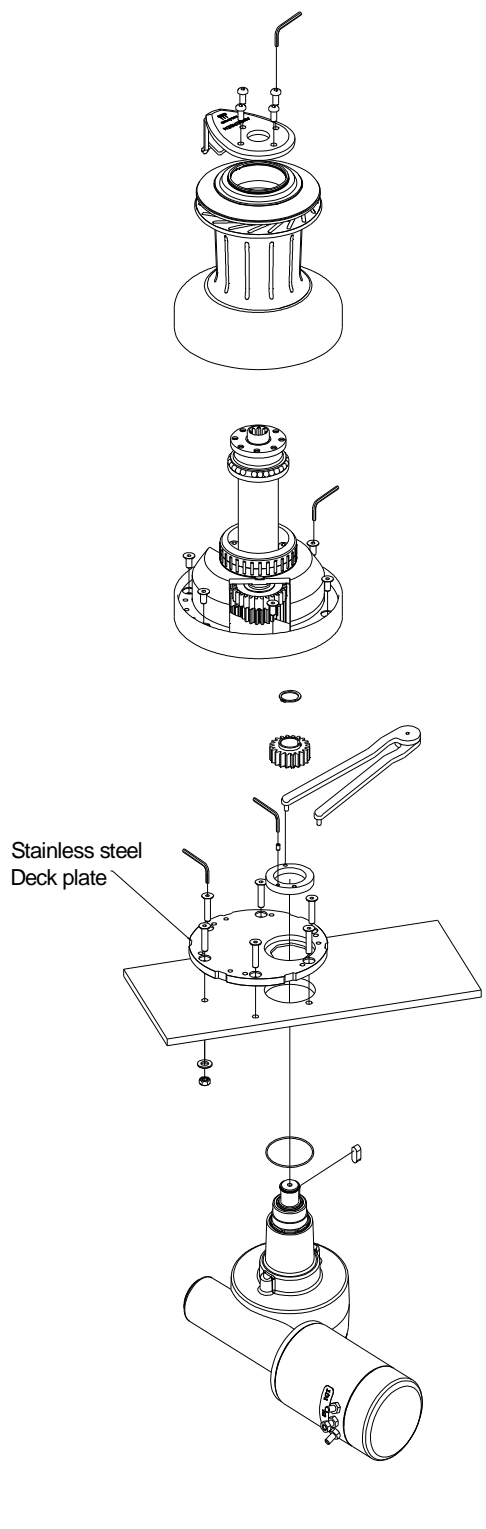

52STE/ STE FS Compact Above Deck

Conversion manual for Compact motor Above Deck.

For above deck compact motors a new lower base is required for winches manufactured before September 2002.

This manual shows how to replace your old lower base with a new, so that older winches will function with the new above deck compact motor.

The numbers below in brackets () refer to the position numbers on the parts list found in the back of the 52ST owners manual. Consult also Figure 6 to see the different parts you will be working with. Be sure to have a clean stable work place while disassembling your winch

1. Remove the winch drum (5) and the Self-tailing arm (2) by removing the 4 bolts (1) on the top on the winch.
2. Remove the 6 x M8 bolts holding the winch to the deck.



Figure 1

3. Remove the drive shaft (6) by sliding it up through the upper base (23) (Figure 1)



Figure 2

4. Remove the 6 bolts (8) holding the upper base (23) to the lower base (26) (Figure 3)



Figure 3

5. Remove the upper base (23) and the bearing (25) (Figure 2)

6. Remove gear wheel (19) by removing screw (17) and then sliding shaft (18) upwards.

7. Remove the complete freewheeling ratchet gear (10-16) by sliding the shaft (9) upwards and pulling the complete freewheeling ratchet gear out to the side. (Figure 4)



Figure 4

8. Remove the second freewheeling ratchet gear (29-35) as in step 7 by removing shaft (28).

9. For base covers (27) in stainless steel remove

10. The base cover (27) by removing the screws holding the base covers to the lower base (26). For base covers (27) in PETP plastic carefully tap the base cover (27) from the lower base (26) with a rubber hammer.

11. Reassemble the winch with the new lower base by reversing the procedure above from 9-3 remembering to apply grease to moving parts.

12. Your winch is ready to be mounted on your new above deck compact motor.



Figure 5



Figure 6: Parts in a 52ST ANDERSEN Winch

58/62STE – STE FS Compact Above Deck

Conversion manual for Compact Above Deck motor.

This manual shows how to replace your old lower base with a new, so that older winches will function with the new above deck compact motor.

The numbers below in brackets () refer to the position numbers on the parts list found in the back of the 58ST ver. 1.5 / 62ST ver. 1.2 , 58/62 ST FS ver. 1.0 owners manual.

Consult also Figure 6 to see the different parts you will be working with. Be sure to have a clean stable work place while disassembling your winch

1. Remove the winch drum (4) and the Self-tailing arm (2) by removing the 4 bolts (1) on the top on the winch.
2. Remove the 6 x M10 bolts holding the winch to the deck.
3. Remove the drive shaft (5) by sliding it up through the upper base (10) (Figure 1)



Figure 9



Figure 7



Figure 8

4. Remove the 6 bolts (15) holding the upper base (10) to the lower base (14) (Figure 3)
5. Remove the upper base (10) and the bearing (13) (Figure 2)
6. Remove the complete freewheeling ratchet gear (17) by sliding the shaft (16) upwards and pulling the complete freewheeling ratchet gear out to the side. (Figure 4)



Figure 10

7. Remove the second freewheeling ratchet gear (18) as in step 6 by removing shaft (16).

8. For base covers (19) in stainless steel remove the base cover (19) by removing the screws holding the base cover to the lower base (14). For base covers (19) in PETP plastic carefully tap the base cover (19) from the lower base (14) with a rubber/plastic hammer. (Figure 5).



Figure 11

9. Reassemble the winch with the new lower base by reversing the procedure above from 8-3 remembering to apply grease to moving parts.

10. Your winch is ready to be mounted on your new above deck compact motor.

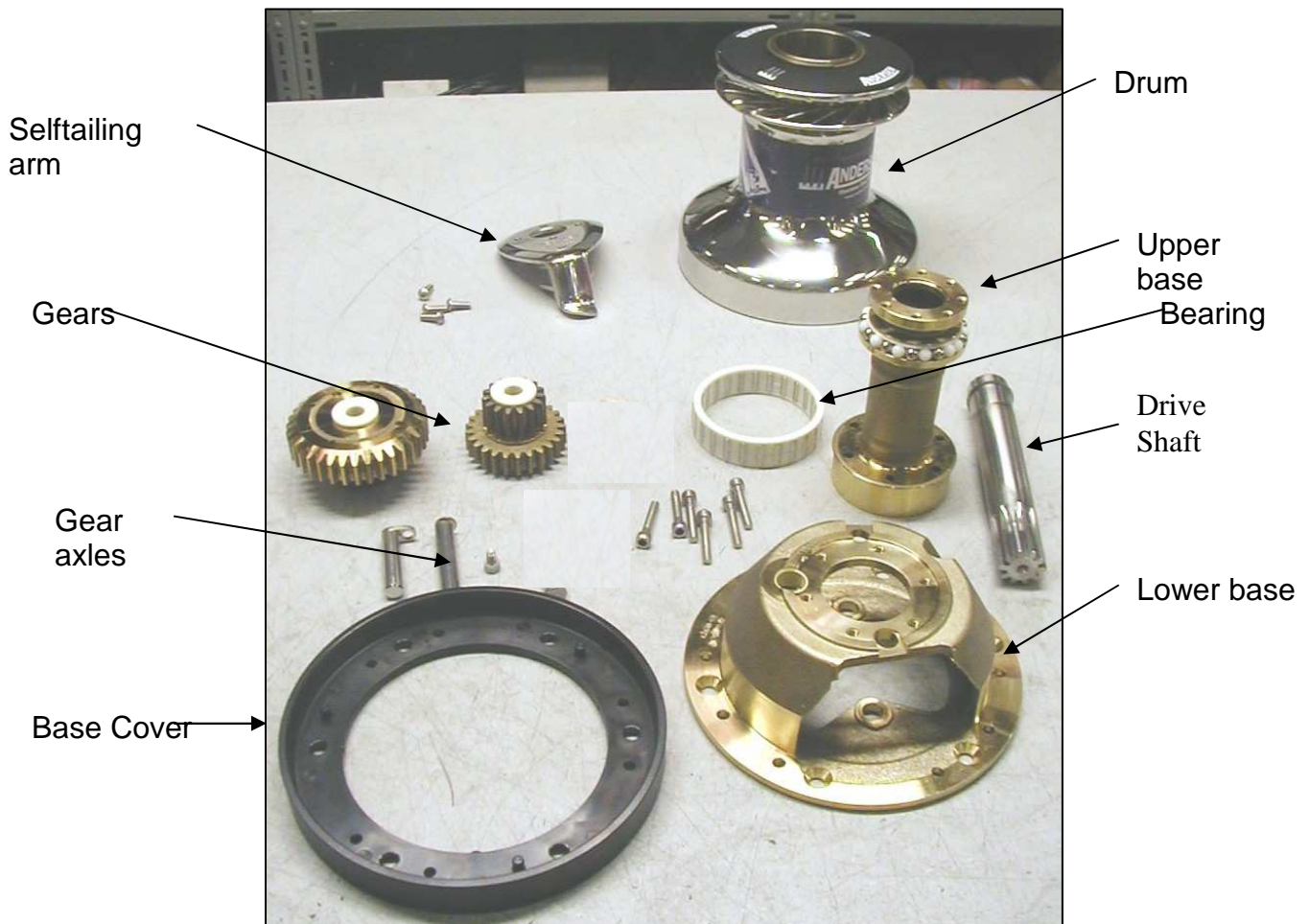

Figure 12: Principle photo of parts in a 58-62ST ANDERSEN Winch

68/72STE Compact

To use your new 68ST compact electric unit with your existing 68ST winch, the existing winch base needs to be swapped with the base supplied with your new unit. Follow the steps below to complete the process.

1. Remove your winch from the boat and find a stable place to work on the winch.



Winch ready for service.

2. Remove the upper base and bearing by removing the screws as shown.



Remove 6 screws
here

3. Pull the shafts up and remove the two sets of ratchet gears.

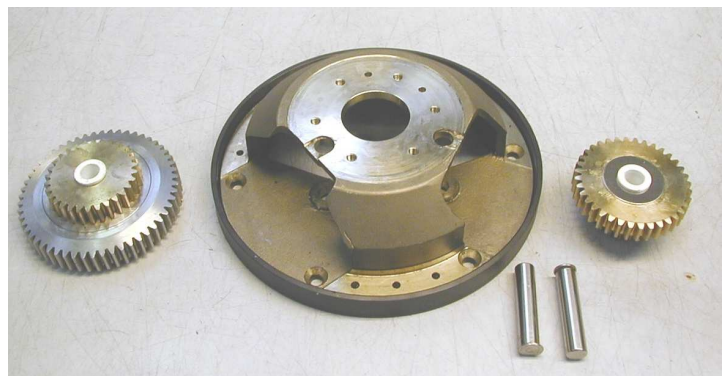
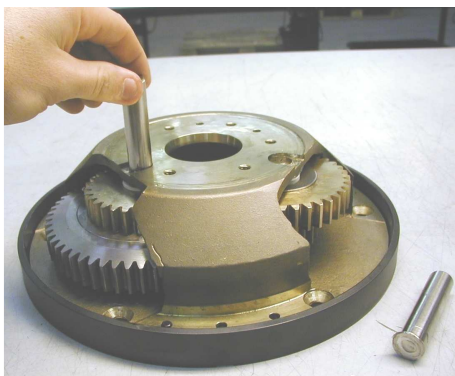

4. Change the screws in the large ratchet gear to those provided. Use a locking paste to secure the new screws.



Old screws



New screws.

5. Reassemble using the new winch base and the altered large ratchet gear



Old Base



New base

6. Your winch can now be connected to your new motor unit.

Worldwide Distribution

ANDERSEN Argentina

Argen Mast & Systems s.r.l.
Av. Tiscornia 963
(1642) San Isidro
Buenos Aires
Tel.: 11 4742 44 62
Fax: 11 4742 44 62
E-mail: info@argenmast.com.ar
Web: www.argenmast.com.ar

ANDERSEN Australia

Allyacht Spars Australia 1853 Lytton Rd.,
Lytton
Queensland
Australia 4178
Tel.: 07 3893 2233
Fax: 07 3893 2478
E-mail: info@allyachtspars.com.au
Web: www.allyachtspars.com.au

ANDERSEN Austria

Robert Lindemann KG
Wendenstrasse 455
D-20537 Hamburg
Tel.: 040 21 11 970
Fax: 040 21 11 97 30
E-mail: info@lindemann-kg.de
Web: www.lindemann-kg.de

ANDERSEN Belgium

Jupiter Handelsmijl. BVBA
Helststraat 51/12
B-2630 Aartselaar
Tel.: 03 457 43 81
Fax: 03 457 68 21
E-mail: info@jachtenjupiter.com
Web: www.jachtenjupiter.com

ANDERSEN Canada

Rekord Marine Enterprises Ltd
8194 Ontario Street
Vancouver, B.C., V5X 3E3
Tel.: 604 325 5233
Fax: 604 325 0326
Toll free fax: 1-800-663-6424
E-mail: jeremy@rekord-marine.com
Web: www.rekord-marine.com

ANDERSEN Croatia

Navela
Castropola 54
HR-52100 Pula
Croatia
Tel.: 052 214 542
Fax: 052 213 558
E-mail: navela@put-com.hr
Web: www.navela.hr

ANDERSEN Czech Republic

Nereide Yachting Ltd.
Vybiralova 972/70
CZ-19800 Prague 9
Tel: 605 25 98 82
Fax: 257 94 17 84
E-mail: office@nereide-yachting.com
Web: www.nereide-yachting.com

ANDERSEN Denmark

WATSKI A/S
Savsvinget 4
DK-2970 Hørsholm
Tel.: 45 76 40 11
Fax: 45 76 40 12
E-mail: kontaktdk@watski.com
Web: www.watski.dk

ANDERSEN Finland

Ky Jotiko-Marine Kb
Unioninkatu 45
SF-00170 Helsinki
Tel.: 103 870 500
Fax: 103 870 509
E-mail: info@jotiko-marine.com
Web: www.jotiko-marine.com

ANDERSEN France

Greement Import – Head office:
13 rue du Chêne Lassé
Z.I. BP 284
44803 Saint Herblain
Tel.: 02 28 03 01 01
Fax: 02 28 03 19 91
E-mail: contact@greementimport.fr
Web: www.greementimport.fr

ANDERSEN Germany

Herman Gotthardt GmbH
Leunastrasse 50
D-22761 Hamburg
Tel.: 040 851 50 50
Fax: 040 850 91 33
E-mail: info@gotthardt-yacht.de
Web: www.gotthardt-yacht.de

ANDERSEN Great Britain

IMP
Jamnan Way
Royston
Hertfordshire SG8 5HW
Tel.: 01 763 241 300
Fax : 01 763 241 770
E-mail: sales@improducts.co.uk
Web: www.improducts.co.uk

ANDERSEN Greece

Meltemi Yachting Ltd.
4, Metamorfoseos st Alimos
GR-17455 Athens
Tel.: 210 9849983
Fax: 210 9844356
E-mail: info@meltemi-yachting.gr
Web: www.meltemi-yachting.gr

ANDERSEN Hong Kong

Storm Force Marine Ltd
1204 Dominion Centre
43-53 Queens Road East
Wanchai, Hong Kong
Tel.: +852 2866 0114
Fax: +852 2866 9260
E-mail: simon@stormforcemarine.com
Web: www.stormforcemarine.com

ANDERSEN Hungary

Marina Yacht Sport
Bécsi út 118. H-1037 Budapest
Tel.: 1 322 86 55
Fax: 1 322 9834
E-mail: iroda@marina.hu
Web: www.marina.hu

ANDERSEN Italy

TOMASONI TOPSAIL S.p.A.
Via E.Toti 55
16035 Rapallo (GE)
Tel.: 0185 2001
Fax: 0185 263 160
E-mail: vela@tomasoni.com
Web: www.tomasoni.com/tecnico

ANDERSEN Netherlands

Nautec Engineering B.V.
Muyteweg 17
6075 AM Herkenbosch
Tel.: 0475 537760
Fax: 0475 537759
E-mail: info@nautec.nl
Web: www.nautec.nl

ANDERSEN New Zealand

Nordic Marketing Ltd.
P.O. Box 100669
NSPS, North Shore City
Tel.: 09 488 7605
Fax: 09 488 7608
E-mail: nordic@extra.co.nz
Web: www.nordic.co.nz

ANDERSEN Norway

Skaane Marine AS
Bromsveien 5
N-3183 Horten
Tel.: 33 02 05 90
Fax: 33 02 05 99
E-mail: post@skaane.no
Web: www.skaane.no

ANDERSEN Poland

Sail Service
ul.Sienna 45
80-605 Gdansk
Tel.: 58 3 222 822
Fax: 58 3 222 802
E-mail: office@sailservice.com.pl
Web: www.sailservice.com.pl

ANDERSEN Portugal

Just Boats
Lote 32, Urb. Goldra
8100-263 Loulé
Tel.: 289 994 204
Fax: 289 994 485
E-mail: info@just-boats.net
Web: www.just-boats.net

ANDERSEN Russia

Yachtglanz - Marine Equipment
Portugiesischer Weg 14
D-44143 Dortmund
Tel.: +49 (0)231 996 48 35
Fax: +49 (0)231 530 74 47
E-mail: info@yachtglanz.com
Web: www.yachtglanz.com

ANDERSEN Singapore

Alquest Marketing
66, Tannery Lane
#02-06B Sindo Building
Singapore 347805
Tel.: 6749 9359
Fax.: 6749 9360
E-mail: jason@alquest.com.sg
Web.: www.alquest.com

ANDERSEN Slovenia

Tramontana
Tesovnikova 88
1000 Ljubljana
Tel.: 01 568 37 32
Fax: 01 565 48 88
E-mail: info@tramontana-net.si
Web: www.tramontana-net.si

ANDERSEN South Africa

Manex & Power Marine
5 Industry Street
P.O. Box 173
Paarden Eiland 7420 Cape Town
Tel.: 021 511 7292
Fax: 021 510 1487
E-mail: manex@manex.co.za

ANDERSEN Spain/Mallorca

Yacht Riggers Mallorca, s.l.
Passeig República Argentina, 34 bajos
E-07200 FELANITX (Mallorca)
Tel.: 971 58 41 30
Fax: 971 58 41 31
E-mail: info@yachtriggers.com
Web: www.yachtriggers.com

ANDERSEN Spain/Barcelona

Pertrechos Nauticos S.L.
Buscarons, 6 bj. local 2
08022 Barcelona
Tel.: 93 418 66 32
Fax.: 93 418 56 48
info@pertrechosnauticos.com
www.pertrechosnauticos.com

ANDERSEN Sweden

Navimo Nordic AB
Lundenvägen 2
S-473 31 Henån
Tel.: 0304 360 60
Fax: 0304 307 43
E-mail: info@navimo.se
Web: www.navimo.se

ANDERSEN Switzerland

Robert Lindemann KG
Wendenstrasse 455
D-20537 Hamburg
Tel.: 040 21 11 97 0
Fax: 040 21 11 97 30
E-mail: info@lindemann-kg.de
Web: www.lindemann-kg.de

ANDERSEN Trinidad & Tobago

Soca Sails
Crewsinn Marina, Chaguaramas
P.O. Box 608
Trinidad, West Indies
Tel.: 868 634-4178
Fax: 868 634-1044
E-mail: info@socasails.com
Web: www.socasails.com

ANDERSEN Turkey

Yenisehir Mahallesi
Bahar Sokak No: 12/9 Blok A2-6
34912 Pendik, Istanbul
Tel.: 533 399 99 77
E-mail: turkey@andersenwinches.com
Web: www.andersenwinches.com

ANDERSEN Ukraine

Yachtglanz - Marine Equipment
Portugiesischer Weg 14
D-44143 Dortmund
Tel.: +49 (0)231 996 48 35
Fax: +49 (0)231 530 74 47
E-mail: info@yachtglanz.com
Web: http://www.yachtglanz.com/

ANDERSEN U.S.A.

Navimo USA, Inc.
7455 16th street E
Suite 107
Sarasota
FL 34243
U.S.A.
Toll-free tel. 866.383.1888
Tel.: 941.360.1888
Toll-free fax 866.214.1400
Fax: 941.360.1648
E-mail: info@navimousa.com
Web: www.navimousa.com

For current distributor list please see www.andersenwinches.com

Andersen Winches, Jaegervænget 36, DK-7100 Vejle, Denmark – tel. +45 76427777 – fax +45 76427788
e-mail: info@andersenwinches.com web: www.andersenwinches.com